

AIRTREND Ltd
Predstavništvo u Beogradu
Kumanovska 14, 11000 Beograd
Tel: 011/3836886, 3085740
Faks: 011/3444113
e-mail: gobrid@eunet.rs
web: www.airtrend.rs

CONTROLS

ISYteq

ISYteq

» EASY TO USE AND COMMISSION CONTROLS
FOR DECENTRAL COMFORT SYSTEMS



ISY IN NAME EASY IN PRACTICE

Providing a comfortable and productive indoor environment for occupants, while maintaining low energy consumption, is of considerable significance for investors, systems builders, planners and architects alike. To achieve these objectives the building technology plays a primary role.

The ISYteq control system combines advanced technology with simple operation and commissioning to ensure maximum comfort and energy efficiency from your ventilation system. FläktGroup can provide everything from Air Handling Units, ultrasound air volume dampers and a variety of fancoil units to advanced control units, and our experience as experts in the field of optimising complete ventilation systems.





Energy efficiency – the essence of our solutions

All our research, development and testing activities are singularly focused to provide our customers with the best and most efficient solutions possible to their ventilation and indoor climate challenges.

From new and innovative concepts, smart material choices and manufacturing processes to advanced controls, minimised running cost and easy maintenance, FläktGroup always strive to deliver the best for your long-term economy and our environment.



ISYteq for Decentralal Comfort Systems

ISYteq TOUCH 4.0 – FOR OPTIMIZING EFFICIENCY WHILE MAINTAINING COMFORT

The ISYteq Touch 4.0 is a microprocessor-based, programmable electronic controller that will enhance the control of any facility and simplify many tasks – whether you are a developer, a building owner, an installer or a facility manager.

The modern tile layout makes navigating the system very easy and the touchscreen offers precision control to enable low fan noise or boost heating and cooling. The display can be dimmed or turned off if the illumination is too bright or operation of the device is not required. Available in black or white frames.



ISYteq LCD IW – FOR SMART LOCAL CONTROL IN COMMERCIAL PROPERTIES

A compact LCD wall mounted controller with a black frame. For navigation of the menu there is a total of 7 touch point buttons on the front of the LCD display. These buttons are all that is needed to set up your system. If the unit is connected to an external controller to choose remote switch off, the device disables local switch on.



These devices can be easily interfaced with most Building Management Systems (BMS) available on the market today to give developers, building owners, designers, installers, facility managers and end users the ideal control solution for optimum performance, usability and energy efficiency with the Flex-Geko, HyPower-Geko, Cassette-Geko or the HyCassette-Geko with unique SWIRL outlet technology.

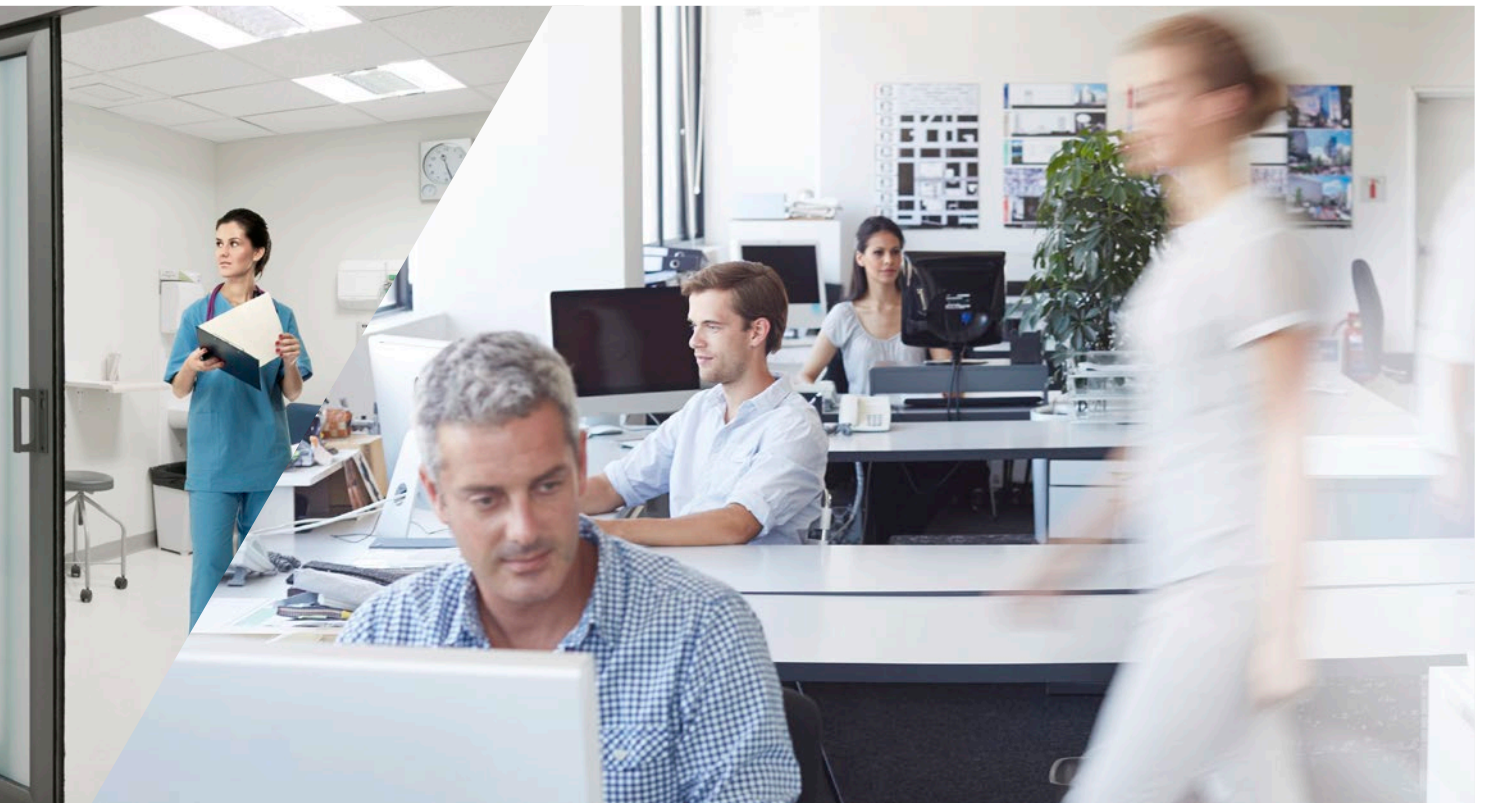

CET.ACEC – FOR COST EFFECTIVE CONTROL OF YOUR FAN COIL UNITS

A more conventional temperature wall switch with or without temperature numbers marked as 10, 20 or 30 degrees for setting the room temperature or just plain with + & - symbols, there is also 3 fan speed settings plus auto fan setting.

ISYteq Touch – packed with features

CONTROLS FEATURES

- Integrated temperature sensor
- Integrated humidity sensor
- By pass mode
- Configurable universal I/O
- Mixed air damper
- Secondary air louvre
- Swirl to regulate air throw
- Temperature set points
- Fan speed
- Alarms
- Anti Lime scale setting
- Sleep button

COMMUNICATION FEATURES

- Ethernet ports
- Built in web server
- BACnet and Modbus
- RS485 Port
- Remote access



DISPLAY FEATURES

- Modern tile layout
- Available with white or black frame
- 64K colour touch screen
- Quick view of room temperature
- Screen shut down
- Symbols on tiles
- Alarms
- Sleep button

OTHER FEATURES

- 90 Mbyte of memory per device
- 1 Month of data storage
- Expansion card available
- Powered by 12-33v DC directly from the controller board
- 230-volt supply for LCD and CETACEC options.
- Flexible and adaptable format
- Standard HTML supported & Java Script
- Display graphs of recorded data by data logger
- Plot data from probes and energy meters
- Easy to set up

SPECIFIC TILE FEATURES INCLUDED IN THE ISYteq TOUCH 4.0



HYCASSETTE-GEKO WITH UNIQUE SWIRL OUTLET TECHNOLOGY TO REGULATE AIR THROW AND PROJECTION ANGLE

- Cold air currents can be uniformly distributed in the room
- The swirl can extend in all directions
- Supports the Coanda effect in cooling operation & counter the thermals of the rising warm air



THE EC FAN ACTION IS PRECISELY CONTROLLED USING THE FAN TILE TO INCREASE OR REDUCE THE FAN SPEED

- Single tile touch to open fan control
- A soft undertone of the fan noise is achieved in the lowest setting
- Mixed air damper mode



OFFERS USERS A MODERN STYLED INTERFACE TOUCH SCREEN WITH EASY TILE FORMAT TO SIMPLIFY USER OPERATION

- Quick view of room temperature
- Symbol identification makes maneuvering through processes easy
- Screen can be switched off when not in use

MULTIPLE SENSORS CAN BE CONNECTED TO THE SYSTEM

- External room temperature sensor
- Return temperature sensor*
- Change over temperature sensor*
- Supply temperature sensor
- Outside air temperature sensor

** These sensors can be ordered to be mounted inside the unit.*



ISYteq-Web

Every FläktGroup unit with a ISYteq control board comes furnished with a full-graphics multilingual visual display system. This visualisation is provided with the web server integrated in the control and can be accessed either via a PC with internet browser or Smartphone app (available for both iOS and Android).

THE VISUALISATION ALLOWS THE FOLLOWING ACTIVITIES:

- Configuration and parameterisation of the plant
- Observation and operation of the plant
- Set-point values
- Viewing the archived measured values
- Display of fault, event, maintenance messages and plant documentation
- Export of the measuring and messages archive for external examination e. g. in Excel
- Backing up and loading the plant parameters
- Monitoring and pre-setting the inputs and outputs.

We have an ISYteq solution to fit any application

SINGLE FAN COIL UNIT INSTALLATION

With a CET.ACEC room controller with built in temperature sensor you have all you need.



There are many applications for which fan coil units are used. Sometimes only a single fan coil unit is required and you may be looking for the most cost effective way to do this. Now all you need is a CET.ACEC with built-in Modbus connection to control up to 4 fan coil units. More demanding environments and complex installations with multiple fan coil units have different requirements where the flexible LCD IW and ISYteq Touch 4.0 can provide an ideal solution.

MULTIPLE UNIT APPLICATION

Ordering the Fan coil units with the 3010 or 3020 controllers fitted enables connection to all the ISYteq interfaces regardless of 1 or multiple units. No software is required for setup with the built-in web browser at your fingers tips. You can even customise the web browser to suit your requirements.



Decisive benefits for all stakeholders



DEVELOPERS & BUILDING OWNERS

- The modern styling will complement and enhance any facility.
- The tiled 64K colour screen makes navigation of the device and system easy and stress-free for users.
- The BACnet & Modbus access allow connections to majority of building management systems (BMS) for whole building view.
- Notifications can be shown in the BMS for immediate attention.
- The 1-month storage allows alarms to be recorded & reviewed and historical data from sensors to be reviewed.
- Add extra sensors like CO₂ and PIR to increase client comfort and save energy.
- Download historical data for examination and action via the webservice.



DESIGNERS

- The modern styling will complement and enhance any facility be it an office building, education establishment or a hotel.
- The tiled 64K colour screen makes navigation of the device and system easy and stress-free for installers and users alike, meaning set up becomes a breeze.
- The built-in web browser allows easy set up with no extra software to purchase.
- The Ethernet LAN access offers limitless device inter-connection and connection to other Flakt Group controllers, so small or large networks can be built for large or small installations.
- BACnet & Modbus access allows connections to most building management systems (BMS) for whole building view, managing set points and alarms, so no large integration costs.
- Alarm notifications can be shown in the BMS for immediate attention and action.
- Because there are no real master or slave units with the controllers, they can work independently which increases the reliability of the system.
- Add extra sensors like CO₂ and PIR for energy management applications.
- The 1-month storage allows alarms to be recorded & reviewed and historical data from sensors to be appraised.
- Display graphs of data recorded by the data logger and plot data from probes and energy meters in real time when connected to BMS.
- The sleep mode reduces the fan operation to a minimum and turns off the screen after 10 seconds. This is ideal for sleep areas like hotel bedrooms or hospitals.
- Anti Lime scale setting to extend system life.



INSTALLERS

- The tiled touch screen makes set up navigation a doddle. Saving you precious time on the installation.
- Control single fan coil units to multiple units with the same group of products.
- Reduction in installation time due to built-in BACnet & Modbus communication protocol.
- Limitless number of connections with Ethernet protocol.
- No costly software to purchase with the built-in web browser.
- Save money by using the standard temperature room controller.
- All units have temperature sensors built in so no costly extras.
- Display graphs of data recorded by the data logger and plot data from probes and energy meters in real time when connected to BMS.
- Utilise standard room controller in a system solution with Modbus connection.
- Increase profit by offering ISYteq Touch 4.0 screen controller panel for more upmarket approach.
- Because there are no real master or slave units, they can work independently which increases the reliability of the system.
- Match customer décor with choice of black or white frame for ISYteq Touch 4.0.



SYSTEM INTEGRATOR

- Reduce installation time with the built in BACnet & Modbus connections.
- No system restrictions with the built-in Ethernet port.
- Display graphs of data recorded by the data logger and plot data from probes and energy meters in real time when connected to BMS.
- Because there are no real master or slave units, they can work independently which increases the reliability of the system.
- The tiled touch screen means there is no special tools required for set up. This saves you precious time on the installation.
- Control single to multiple fan coil units with the same products.
- The in-built web browser means no costly software to purchase.
- Customise the web browser to suit your customer.
- Save money by using the standard temperature room controller.
- Utilise standard room controller in a system solution with Modbus connection to the inbuilt controller reducing set up time for your system solution.
- I/O expansion units for flexibility and more connections
- Increase your profit when offering ISYteq Touch 4.0 screen controller panel for more stylish and upmarket approach.
- Match customer décor with choice of black or white frame for ISYteq Touch 4.0
- Quick and easy to connect other sensors such as PIR and CO₂ for energy management.



FACILITY MANAGER

- Avoid connection & communication problems with built in BACnet connection when refurbishing your site, saving time & money.
- Remove concerns of local interference to set points etc. with the ability to switch off the LCD IW remotely.
- Upscale your installation with the Touch 4.0 in black or white.
- You can customise the built-in web browser to suit you.
- Display graphs of data recorded by the data logger and plot data from probes and energy meters in real time.
- Utilise ISYteq from single units to multiple units for large system solution.
- Add other multiple sensors such as CO₂ and PIR to increase customer comfort and reduce energy.

Technical information | ISYteq Touch 4.0



TOUCH DISPLAY

Display size	4,3"
Length / width (mm)	151,5 / 87,7
Power supply	12-33 VDC
Backlight	LED
Protection class	IP40 (front)
Working temperature	0°C to + 50°C
Storage temperature	-30°C to + 70°C
Integrated temperature sensor	Yes
Integrated humidity sensor	Yes

The ISYteq Touch 4.0 is connected directly to the PCB controller and is powered by this connection. It is available in either flush mounting or surface mounting.

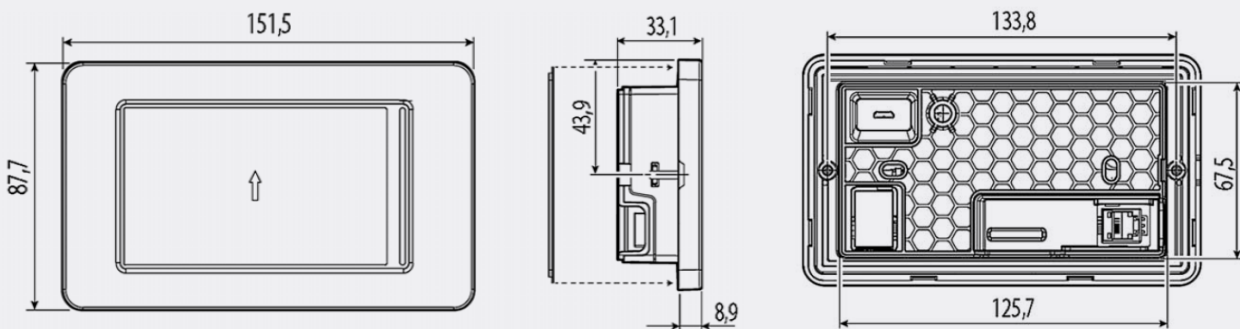

ISYteq Touch 4.0 surface mounting

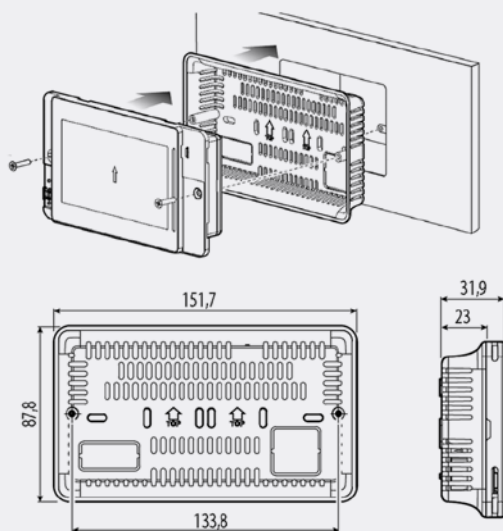

ISYteq Touch 4.0 flush mounting

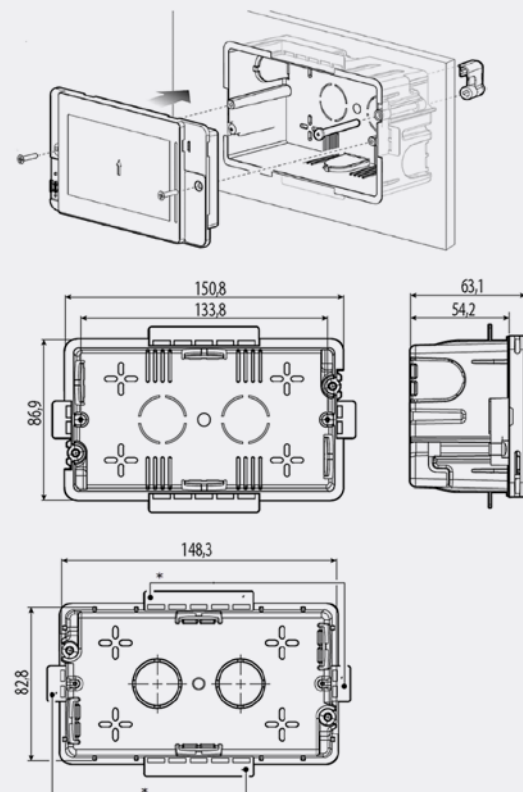

Technical information | ISYteq LCD IW



LCD DISPLAY

Length / width (mm)	86 x 86
Power supply	230 VAC (+10/-15%) 50/60 Hz
Maximum Current	2 VA
Protection class	IP20
Working temperature	-10°C to + 60°C
Storage temperature	-20°C to +70°C

The LCD IW require a direct connected 230-volt supply.

Technical information | CET.ACEC



CET.ACEC

Length / width (mm)	84 x 114
Power supply	230 VAC 50/60 Hz
Protection class	IP30
Working temperature	0°C to + 50°C
Storage temperature	-15°C to +65°C

The CET.ACEC is a surface mounted room controller which requires a direct 230-volt supply.

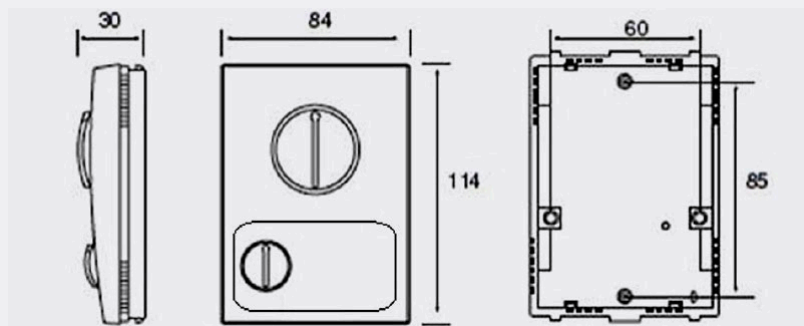

PCB Fan Coil unit controller is available in the following:

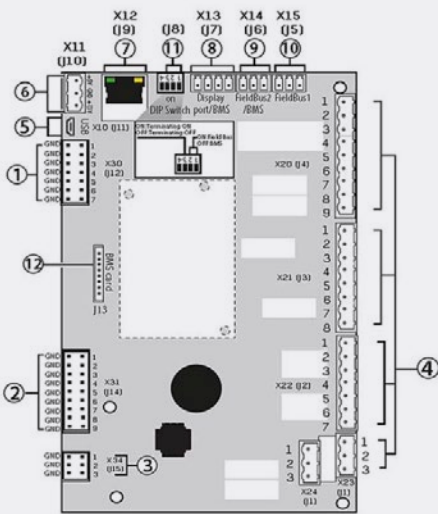

ISYteq 3010 CONTROLLER

Ref.	Description
1	J12: Digital inputs
2	J14: Analogue inputs
3	J15: Analogue outputs
4	J1, J2, J3, J4: Digital outputs
5	J11: Micro USB for application upgrade
6	J10: Power supply for external probe
7	J9: Ethernet port
8	J7: Display port
9	J6: BMS/Fieldbus 2 port
10	J5: Fieldbus 1 port
11	J8: DIP Switch BMS/Fieldbus 2 port configuration
12	J13: BMS card (optional)

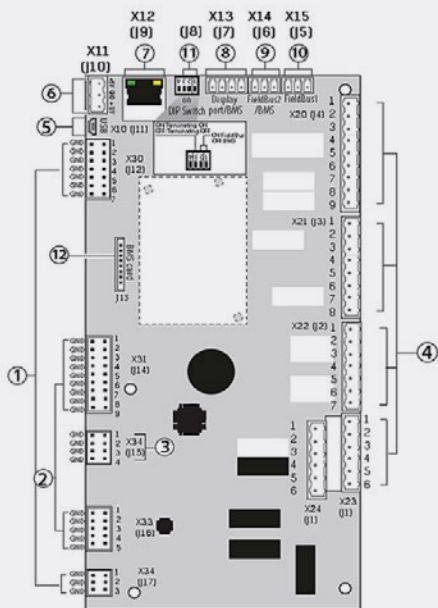

ISYteq 3020 CONTROLLER

Ref.	Description
1	J12: Digital inputs
2	J14: Analogue inputs
3	J15: Analogue outputs
4	J1, J2, J3, J4: Digital outputs
5	J11: Micro USB for application upgrade
6	J10: Power supply for external probe
7	J9: Ethernet port
8	J7: Display port
9	J6: BMS/Fieldbus 2 port
10	J5: Fieldbus 1 port
11	J8: DIP Switch BMS/Fieldbus 2 port configuration
12	J13: BMS card (optional)

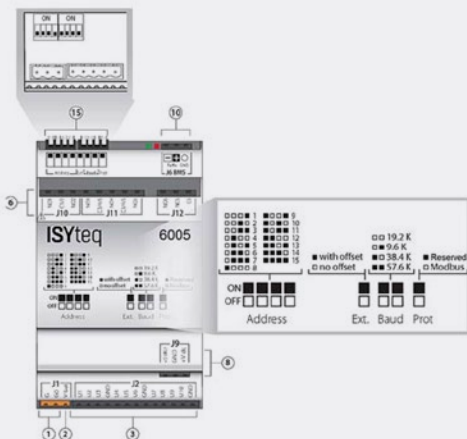

ISYteq 6005 EXPANSION CARD

To increase the number of inputs/outputs on the controller and the number of relays an extension card can be added.

Ordering information



PART NUMBER

ISYteq Touch 4.0 BF-P (with black frame)

ISYteq Touch 4.0 WF-P (with white frame)

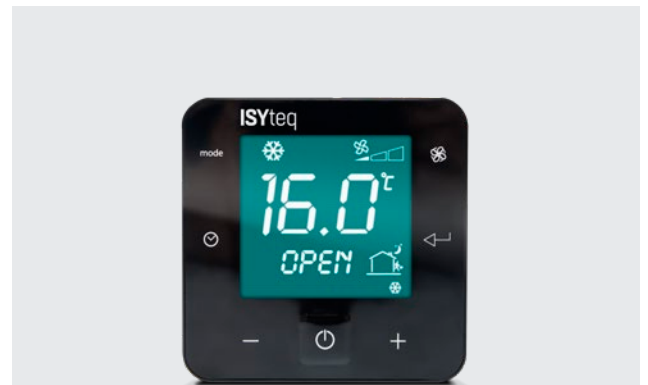

PART NUMBER

ISYteq LCD IW



PART NUMBER

CET.ACEC (standard execution)

CET.ACEC REL.COVP-P (standard execution with relative temperature scale cover 9)

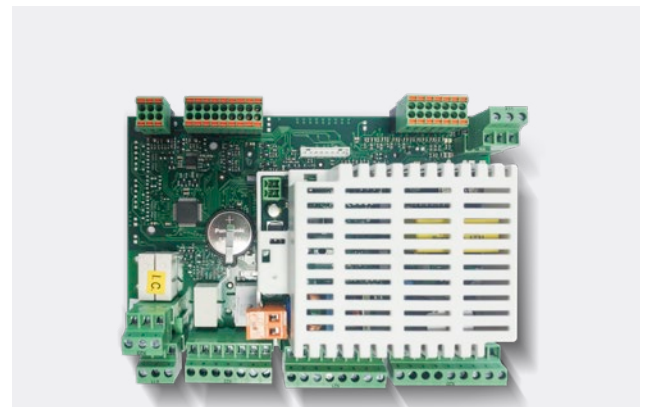

PART NUMBER

ISYteq 3010

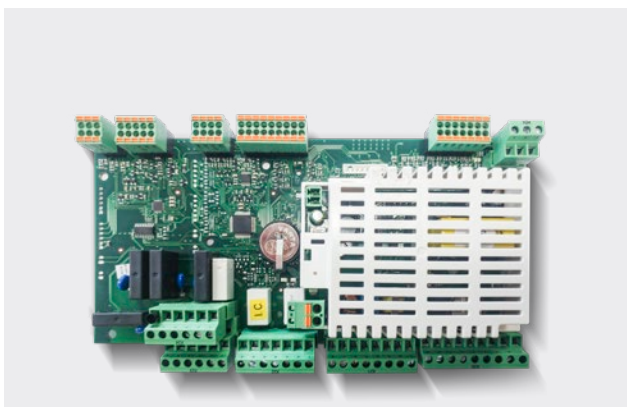

PART NUMBER

ISYteq 3020

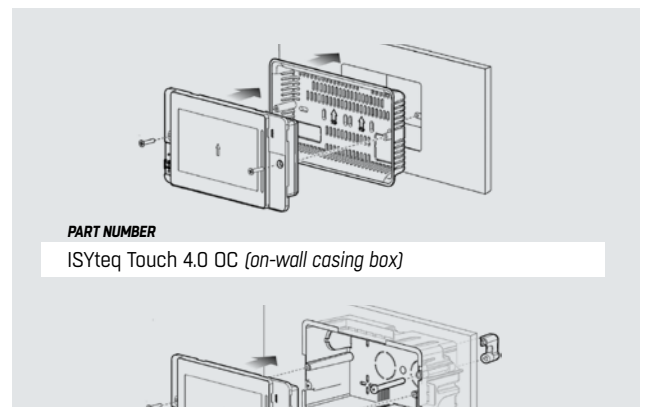

PART NUMBER

ISYteq Touch 4.0 OC (on-wall casing box)

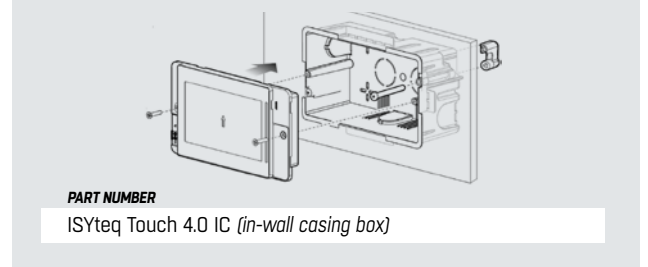

PART NUMBER

ISYteq Touch 4.0 IC (in-wall casing box)

Electrical connection – Network connections

ISYteq network and Building Management connections

This section contains information about the ISYteq Network and the correct network setup. The ISYteq Network is a network based on BAC-Net for connecting various components of the ISYteq control system (network users) in one data bus. The bus enables the exchange of all information required for control and regulation between the users.

Group structure

A network can consist out of a minimum of 2 and a maximum of 64 units (ISYteq controllers). The maximum

number of units in one room should not exceed 16 units.

Maximum amount of group depends on the size of the largest group

This network is constructed in that way that there are no real master or slave units, they can work independently. It can be setup in that way that one controller passes on information to the other controllers, which is a classical master-slave setup, but if the communication is somehow lost they can run on themselves if they have enough information (eg room temperature etc.).

ETHERNET NETWORK CONNECTIONS

Connection via Ethernet port using a switch

The built-in Ethernet ports on the ISYteq controller can be used to create multimaster and multiprotocol networks, with transmission speeds up to 100 Mbps. The controllers can be connected together via an external switch (see figure to the right).

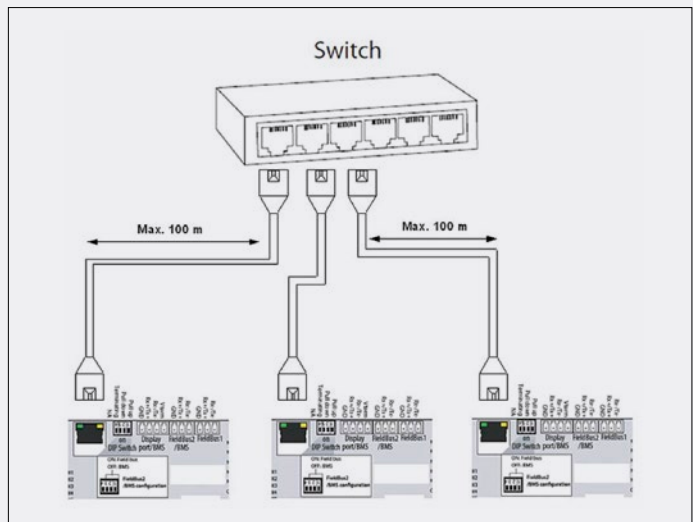

Structure and topologies of ISYteq network with BACnet TCP/IP

An Ethernet network doesn't have any limitations in the number of groups and doesn't need any terminations.

Line structure for serial ISYteq network with BACnet MSTP

The illustration shows the setup of the ISYteq network with line structure. As an example, two groups, each consisting of one ISYteq controller are networked.

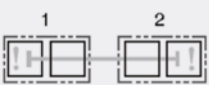

As an example, two groups, each consisting of one ISYteq controller are networked.

NOTICE!
The data transfer cable must be run as demonstrated in the figure to the right, one side of the respective shielding is applied.

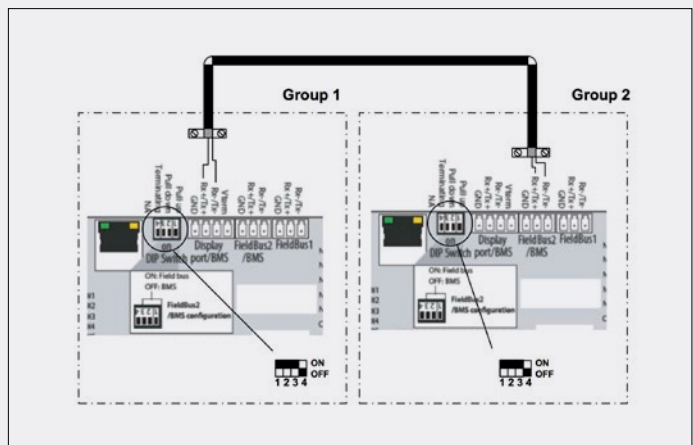

RS485 NETWORK

Connecting master unit with slave units using a serial connection

A master/slave network of ISYteq controllers can be created by using the RS485 serial ports.

Such networks comprise:

One ISYteq controller (Master) that communicates via the Fieldbus RS485 serial port using the BACnet MSTP protocol;
 One or more ISYteq controllers (Slaves) connected to the point-to-point network via the BMS RS485 serial port using BACnet MSTP protocol;

- Connect the control cables in accordance with the wiring diagram.
- The max. length allowed for the network is 1000 m. If the network is longer than 100 m, apply the 120Ω, 1/4W terminating resistors to the first and last devices in the network.
- The following cable is recommended for the bus line:
 Type: Li2YCYC TP flexible 2 x 2 x 0,5 mm²

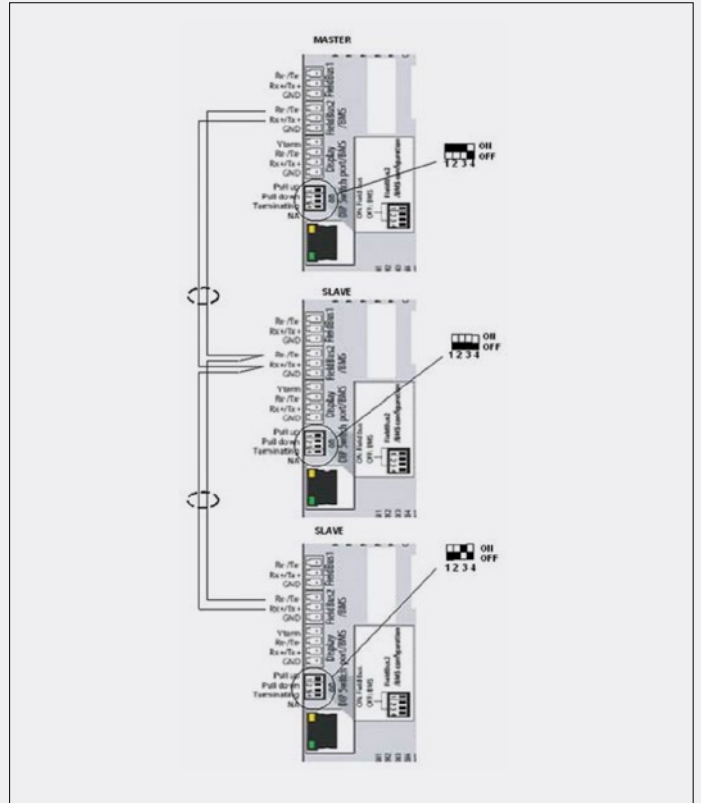

Structure and topologies of ISYteq network with BACnet MSTP

A serial network can consist of one or several (up to 32) groups and can be set in a line structure with branch feeder. All ISYteq controllers can access this data bus. With serial communication the data bus must be terminated at both physical ends to avoid reflections which can interfere with data transfer. Switchable bus terminating resistors are integrated on the respective boards enabling safe termination.

The maximum possible number of groups depends on the largest group in the network. 64 serial nodes should be divided by the number of devices in the largest group. This is the maximum possible number of groups.

Example calculation:

Largest group consist of 6 devices.

64 nodes / 6 devices = 10,67 maximum number of groups 10

Largest group size	Maximum amount of groups (BACnet MSTP only)
1	32
2	32
3	21
4	16
5	12
6	10
7	9
8	8
9	7
10	6

Performance characteristics check list

THE FOLLOWING PERFORMANCE CHARACTERISTICS ARE INCLUDED:

Unit Type	2 pipe system: only heating, only cooling, heating or cooling 4 pipe system: heating and cooling
Fan	Up to 3 speeds Continuous (EC motor) Temperature related fan speed control Air quality related fan speed control (fresh air units) Minimum speed 1 Motor protection / EC motor alarm Auto mute function (limited maximum fan speed)
Valve control	2 and 4 pipe system: 2 point valve actuators (on/off) 2 and 4 pipe system: 3 point modulating valve actuators Silent valve control (semi-conductor relay) External heating or cooling valve control with fan off
Electrical heater	1 step control 2 step control Safety temperature limitation (supply air) Delayed fan stop Modulating control (0-10V) Safety temperature alarm
Frost protection	Room frost protection Auto wake up function Frost protection thermostat
Control mode	Room temperature control Supply temperature control Min. / Max. supply temperature limitation Outside air temperature curve Summer / Winter compensation Room-Supply cascade temperature control
Sensors	Supply temperature sensor Room temperature sensor Return temperature sensor Outside temperature sensor CO2 air quality sensor VOC air quality sensor Filter differential pressure switch Filter differential pressure sensor
External signals / messages	Unit on/off Profile mode input (configurable unit mode) Alarm message output Unit operation message output Cooling demand (digital / analog) Heating demand (digital / analog)
Condensate	Condensate high level alarm Start condensate pump Anti-condensate monitoring
Chiller / Heat pump	Chiller control (2 stage) Inverter heat pump control (2 units)
BMS connections	Modbus RS485 / TCP-IP (Standard) BACnet MSTP / TCP-IP (Standard) LDN (optional) KNX (optional)
Special functions	Geko Drive control Swirl control Secondary air louvre control
Mixing air control	Mixing air damper control (on/off) Mixing air damper control (modulating)



FläktGroup fan coil range

FläktGroup fan coil units offer all possibilities of a demand-controlled technology and can be employed everywhere, where comfortable warmth, cooling or air ventilation with a rapid adaptation is required. We have more than 40 years of experience creating fan coils for customised air quality with extremely low-noise operation and maximum energy efficiency. Our fan coils offer state-of-the-art technology and certified quality, while of course being compliant with current legal directives. *Learn more about our fan coil range at www.flaktgroup.com*



HyCASSETTE-GEKO

With the highest comfort standards, intelligent control system and attractive design, this system is the answer to all your air handling requirements.

- Optimal room temperature control system
- Homogenous temperature distribution
- Easy to clean and disinfect

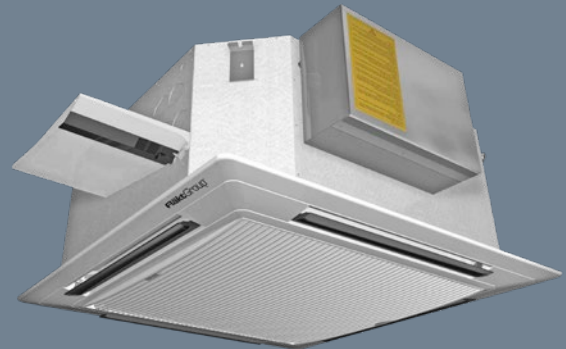

CASSETTE-GEKO

Compact fan coil unit with high cooling capacity for comfort air treatment.

- Low noise level
- Low energy consumption
- Easy installation and service friendly

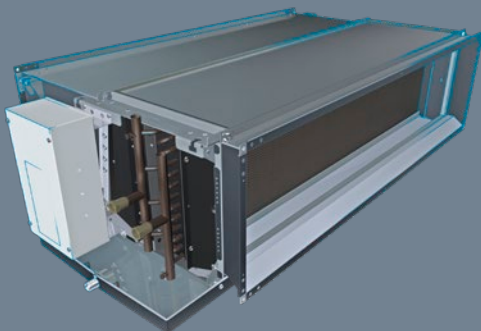

HyPOWER-GEKO

The new top performing HyPower units ventilate, heat or cool depending on the requirements. Their maximum cooling capacity is 25 kW. HyPower is pressure resistant up to 150 Pa.

- Optically inconspicuous installation above a suspended ceiling
- Powerful – equipped with a highly pressure resistant fan
- Easy to control – EC Motors for continuously variable ventilator speed



FLEX-GEKO

Flexible unit for different installations in a wall, ceiling or suspended ceiling.

- Highest flexibility in mounting, air directions and accessories
- Low noise level
- Low energy consumption
- Easy installation and service friendly

EXCELLENCE IN SOLUTIONS

WWW.FLAKTGROUP.COM

ISYteq 10208

FläktGroup is the European market leader for smart and energy efficient Indoor Air and Critical Air solutions to support every application area. We offer our customers innovative technologies, high quality and outstanding performance supported by more than a century of accumulated industry experience. The widest product range in the market, and strong market presence in 65 countries worldwide, guarantee that we are always by your side, ready to deliver Excellence in Solutions.

PRODUCT FUNCTIONS BY FLÄKTGROUP

Air Treatment | Air Movement | Air Diffusion
Air Distribution | Air Filtration | Air Management & ATD's
Air Conditioning & Heating | Controls | Service

» Learn more on www.flaktgroup.com
or contact one of our offices

